

MICROWAVE SENSOR FOR SURFACE MOUNTING**MODEL: MSOM20****INSTRUCTIONS FOR EXPLOITATION**

Radar sensor uses frequency-modulated waves to detect moving and still objects. It detects the presence in its controlled area and turns on/off the electrical circuit accordingly.

The technology used in radar sensors has higher movement sensitivity and bigger detection range, compared to infrared sensors. The radar sensor signal can pass freely through wood, glass and thinner walls.

TECHNICAL SPECIFICATIONS

Voltage:	220-240 V AC / 50-60 Hz
Ambient Light:	<3-2000 lx (adjustable)
Time Delay:	min. 10sec±3sec. / max. 12min ±1min
Rated Load:	1200W (incandescent lamps) / 300W (energy-saving lamps)
Detection Range:	360°
Detection Distance:	1 - 9 m (radius) adjustable
HF System:	5.8GHz CW radar, ISM band
Transmission Power:	<0.2mW
Installation Height:	1.5-3.5m
Power Consumption:	approx0.9W
Detection Motion Speed:	0.6-1.5m/s
Working Temperature:	-20°C +40°C
Working Humidity:	<93%RH
IP rate:	IP20

FUNCTION

- **Identifying day and night:** It can work in daytime and at night when it is adjusted on the "sun" position (max). It can work in the ambient light less than 3lx when it is adjusted on the "3lx" position (min). As for the adjustment pattern, please refer to the testing pattern.
- **Adjusting SENS:** It can be adjusted according to the location. The detection distance of low sensitivity could be only 1m and high sensitivity could be 9 m which fits for large room.
- **Adjusting TIME DELAY:** It can be set according to the consumer's desire. The minimum time is 10sec±3sec. The maximum is 12min±1min. When it receives the second induction signals within the first induction period, it will compute time once more on the basic of the first time-delay reset.

TAKING CARE OF THE NATURAL ENVIRONMENT CLEANLINESS

- The product and its components are not harmful to the environment
- Please dispose the package elements separately in containers for the corresponding material.
- Please dispose the broken product separately in containers for out of usage electrical equipment.

INSTALLATION

- Turn off the power supply.
- Loosen the up cover anti-clockwise to unload it.
- Fix the bottom on the selected position.
- Connect the power and load wire into connection-wire column according to the connecting figure.
- Twist the upper cover clockwise. Switch On the power and test it.

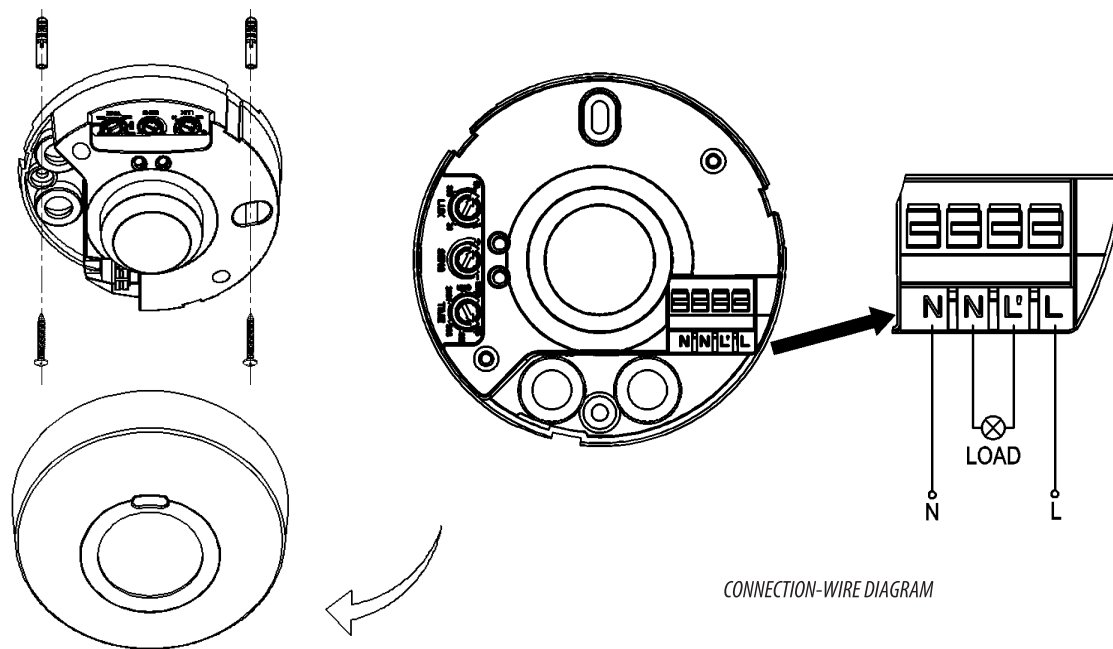

CONNECTION-WIRE DIAGRAM

TEST

- Turn the LUX knob clockwise on the maximum. Turn the TIME knob anti-clockwise on the minimum. Turn the SENS knob clockwise on the max.
- When you switch on the power, the light will be on at once. And 10sec±3sec later the light will be off automatically. Then if the sensor receives induction signal again, it can work normally.
- Turn LUX knob anti-clockwise on the minimum. If the ambient light is less than 3 lx, the inductor load could work when it receives induction signal.

Note: When testing in daylight, please turn LUX knob to (SUN) position, otherwise the sensor light could not work

PROBLEMS AND TROUBLESHOOTING**1. THE LOAD DOES NOT WORK**

- Check the power and the load.
- Whether the indicator light is turned on after sensing? If yes, please check load.
- If the indicator light is not on after sensing, please check if the working light corresponds to the ambient light.
- Please check if the working voltage corresponds to the power source.

2. THE SENSITIVITY IS POOR

- Please check if in front of the sensor there is an obstructive object that can affect the receiving of the signals.
- Please check if the signal source is in the detection fields.
- Please check the installation height.

3. THE SENSOR CAN'T SHUT AUTOMATICALLY THE LOAD

- If there are continual signals in the detection fields.
- If the time delay is set to the longest.
- If the power corresponds to the instruction.

NOTES**NOTES****NOTES****NOTES****NOTES**

- MUST BE INSTALLED BY A TECHNICALLY QUALIFIED PERSON.
- CANNOT BE INSTALLED ON THE UNEVEN AND SHAKY SURFACE
- IN FRONT OF THE SENSOR THERE SHOULDN'T BE OBSTRUCTIVE OBJECT AFFECTING DETECTION.
- AVOID INSTALLING IT NEAR THE METAL AND GLASS WHICH MAY AFFECT THE SENSOR.
- FOR YOUR SAFETY, PLEASE DON'T OPEN THE CASE BEFORE SWITCHING OFF THE POWER SUPPLY, IF YOU FIND A PROBLEM AFTER INSTALLATION.
- IN ORDER TO AVOID THE UNEXPECTED DAMAGE OF PRODUCT, PLEASE ADD A SAFE DEVICE OF CURRENT 6A WHEN INSTALLING MICROWAVE SENSOR, FOR EXAMPLE, FUSE, SAFE TUBE ETC.